

# AT03-AT05 SERIES OILLESS COMPRESSORS

## OPERATION & MAINTENANCE MANUAL



Thank you for purchasing this product. It is manufactured to the highest standards using quality materials. Please follow all recommended maintenance, operational and safety instructions and you will receive years of trouble free service.



### WARNING



**PLEASE READ THIS MANUAL COMPLETELY BEFORE INSTALLING AND USING THIS PRODUCT. SAVE THIS MANUAL FOR FUTURE REFERENCE AND KEEP IN THE VICINITY OF THE PRODUCT.**

#### Product Use Criteria:

- Pump only clean, dry air.
- Operate at 32°F - 104°F (0°C - 40°C).
- Protect unit from dirt & moisture.
- Do not pump flammable or explosive gases or use in an atmosphere that contains such gases.
- Protect all surrounding items from exhaust air. This exhaust air can become very hot.
- Corrosive gases and particulate material will damage unit. Water vapor, oil-based contaminants or other liquids must be filtered out.
- Consult manufacturer before using at high altitudes.
- Oil-Less rotary-vanes require NO lubrication.
- Sealed bearings are grease packed.
- Use of petroleum or hydrocarbon products will reduce carbon-vane service life.



ISO 9001 & 14001 CERTIFIED

[www.gastmfg.com](http://www.gastmfg.com)

**Your safety and the safety of others is extremely important.**

We have provided many important safety messages in this manual and on your product. Always read and obey all safety messages.



This is the safety alert symbol. This symbol alerts you to hazards that can kill or hurt you and others. The safety alert symbol and the words "DANGER" and "WARNING" will precede all safety messages. These words mean:

## **DANGER**

You **will** be killed or seriously injured if you don't follow instructions.

## **WARNING**

You **can** be killed or seriously injured if you don't follow instructions.

All safety messages will identify the hazard, tell you how to reduce the chance of injury, and tell you what can happen if the safety instructions are not followed.

## INSTALLATION

### **WARNING**



#### **Electrical Shock Hazard**

Disconnect electrical power at the circuit breaker or fuse box before installing this product.

Install this product where it will not come into contact with water or other liquids.

Install this product where it will be weather protected.

Electrically ground this product.

Failure to follow these instructions can result in death, fire or electrical shock.

**Correct installation is your responsibility.** Make sure you have the proper installation conditions and that installation clearances do not block air flow.

**Blocking air flow over the product in any way can cause the product to overheat.**

#### **Mounting**

This product can be installed in any orientation. Mounting the product to a stable, rigid operating surface and using shock mounts will reduce noise and vibration.

#### **Plumbing**

Remove plugs from the IN and OUT ports. Connect with pipe and fittings that are the same size or larger than the product's threaded ports. Install relief valves and gauges at inlet or outlet, or both, to monitor performance. Check valves are required to prevent back streaming through the pump.

#### **Motor Control**

It is your responsibility to contact a qualified electrician and assure that the electrical installation is adequate and in conformance with all national and local codes and ordinances.

Determine the correct overload setting required to protect the motor (see motor starter manufacturer's recommendations). Select fuses, motor protective switches or thermal protective switches to provide protection. Fuses act as short circuit protection for the motor, not as protection against overload. Incoming line fuses help to withstand the motor's starting current. Motor starters with thermal magnetic overload or circuit breakers protect motor from overload or reduced voltage conditions.

The wiring diagram attached to the product provides required electrical information. Check that power source is correct to properly operate the dual-voltage motor.

## OPERATION

### **WARNING**



#### **Injury Hazard**

Product surfaces become very hot during operation, allow product surfaces to cool before handling.

Air stream from product may contain solid or liquid material that can result in eye or skin damage, wear proper eye protection.

Do not pump flammable or explosive gases or use in atmospheres that contain such gases.

Failure to follow these instructions can result in fire, burns, eye injury or other serious injury.

It is your responsibility to operate this product at recommended pressures or vacuum duties and room ambient temperatures.

Model numbers ending in "X" have automatic thermal protectors which protect the motor by shutting the motor off if it overheats. The motor will automatically restart once the motor has cooled.

#### **Start Up**

If motor fails to start or slows down significantly under load, shut off and disconnect from power supply. Check that the voltage is correct for motor and that motor is turning in the proper direction. Vane life will be drastically reduced if motor is not operating properly. Vanes can break or be damaged if motor/pump runs in the wrong direction.

## MAINTENANCE

### **WARNING**

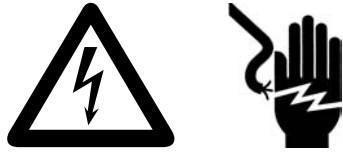

#### **Electrical Shock Hazard**

**Disconnect electrical power supply cord before performing maintenance on this product.**

**If product is hard wired into system, disconnect electrical power at the circuit breaker or fuse box before performing maintenance on this product.**

**Failure to follow these instructions can result in death, fire or electrical shock.**

### **WARNING**



#### **Injury Hazard**

**Wear eye protection when flushing this product.**

**Air stream from product may contain solid or liquid material that can result in eye or skin damage.**

**Flush this product in a well ventilated area.**

**Do Not use kerosene or other combustible solvents to flush this product.**

**Failure to follow these instructions can result in eye injury or other serious injury.**

**It is your responsibility to:**

- Regularly inspect and make necessary repairs to product in order to maintain proper operation.
- Make sure that pressure and vacuum is released from product before starting maintenance.

Check intake and exhaust filters after first 500 hours of operation. Clean filters and determine how frequently filters should be checked during future operation. This one procedure will help to assure the product's performance and service life.

#### **General Maintenance**

1. Remove end cap and filters. Inspect filters for rips, tears, cuts, brittleness and excessive foreign material.
2. Clean filters if in good condition with compressed air. Re-inspect for wear conditions. Set filters aside.
3. Check both internal and external filter felts (#8 and #11 on exploded view) for foreign material. If felts are dirty or worn, replace with new felts.
4. Check condition of O-ring on internal filter. It should be soft and flexible. Replace if it is not.
5. Remove and inspect muffler box. Clean box. Set box aside. (Not all models have a muffler box.)
6. Check gasket for cracks or tears. Install new gasket if any cracks or tears appear. Replace gasket.
7. Reinstall muffler box. Torque bolts to 90-120 in. lb.
8. Reinstall filters or install new filters if required. Reinstall end cap finger tight.

#### **Flushing**

Flushing this product to remove excessive dirt, foreign particles, moisture or oil that occurs in the operating environment will help to maintain proper vane performance. There are 2 options for this operation. If Option 1 does not remedy your problem, go on to Option 2.

**Use only Gast Flushing Solvent or other non-petroleum based flushing solvent. Do Not use kerosene or ANY other combustible solvents to flush product.**

#### **Option 1**

You will need 2 pipe nipples at least 4 inches long with appropriate thread size for the unit involved. No nipples are needed if the unit does not have a muffler box.

1. Remove filter and muffler cap (#9).
2. Remove 5 bolts. Use a small hammer to tap on muffler box to remove it. Attach pipe nipples where muffler caps were removed.
3. Start product and add flushing solvent to the inlet port. If using liquid solvent, pour several tablespoons directly into the inlet port. If using Gast spray solvent, spray for 5-10 seconds into inlet port. Place towel over exhaust port to clean up solvent.
4. Plug inlet port for 20-30 seconds. Listen for changes in the sound of the pump. If pump sounds smooth, go to next step. If pump does not sound like it is running smoothly, installing a Service Kit will be required (See Service).
5. Release vacuum.
6. Repeat steps 3-5 three or four times.

**If Option 1 is not successful, remove the end plate and examine.**

#### **Option 2**

1. Remove six end plate bolts. (See exploded view.)
2. Use a small hammer to carefully tap on end plate to remove. Do not use a screwdriver to pry off.
3. Check that vanes are moving freely in and out of vane slots. Replace vanes if more than 50% of the vane extends past the vane slot.
4. Remove vanes and clean both sides with fine emery cloth. Clean end-plate with fine emery cloth.
5. Flush vanes with solvent and remove all solvent from vanes.
6. Flush body, rotor and end plate with solvent, then remove all solvent from each part.
7. Check body, rotor and end plate for scoring. If each part is clean and shows no signs of scoring, re-install parts. If scoring appears, send unit to factory or replace with new part(s).
8. Insert vanes, checking that the bevel edges are in the correct direction.
9. Replace end plate. Torque bolts to 90-120 in. lb.
10. Check gasket for damage.
11. Reinstall muffler box. Torque bolts to 90-120 in. lb.

**Check that all external accessories such as relief valves and gauges are attached to cover and are not damaged before re-operating product.**

## SHUTDOWN PROCEDURES

**It is your responsibility to follow proper shutdown procedures to prevent product damage. NEVER ADD OIL TO THIS OIL-LESS PUMP.**

1. Disconnect plumbing.
2. Operate product for at least five minutes without plumbing.
3. Run at maximum vacuum for 10-15 minutes.
4. Repeat step 2.
5. Disconnect power supply.
6. Plug open ports to prevent dirt or other contaminants from entering product.

## SERVICE KIT INSTALLATION

### **WARNING**



#### **Electrical Shock Hazard**

**Disconnect electrical power supply cord before installing Service Kit.**

**If product is hard wired into system, disconnect electrical power at the circuit breaker or fuse box before installing Service Kit.**

**Vent all air lines to release pressure or vacuum.**

**Failure to follow these instructions can result in death, fire or electrical shock.**

**Manufacturer will NOT guarantee field-rebuilt product performance. For performance guarantee, the product must be returned to the manufacturer.**

Service Kit contents vary. Most contain vanes, gaskets and filter parts.

1. Remove filter/muffler parts from front of muffler box.
2. Remove the 5 muffler box bolts.
3. Use a small hammer to tap on box to remove. Do not use a screwdriver.
4. Remove the 6 end plate bolts.
5. Remove end plate. Check direction of bevel edges of vanes then remove vanes.
6. Clean body and rotor slots with Gase flush solvent or equivalent flushing solvent. Hand turn the rotor to make sure it rotates freely. Any unusual grinding or scraping sound could indicate worn bearings or scored parts.
7. Check end plate, rotor and body for scoring. Severe scoring or worn bearings will require service at the manufacturer.

**DO NOT remove rotor or motor bolts.**

8. Insert vanes, checking that the bevel edges are in the correct direction. See diagram below.
9. Replace end plate. Torque bolts to 90-120 in. lb.
10. Check gasket for damage.
11. Reinstall muffler box. Torque bolts to 90-120 in. lb.

**Check that all external accessories such as relief valves and gauges are attached and are not damaged before re-operating product.**

**The vanes need to be flush with the curvature of the rotor when installing.**



# EXPLODED PRODUCT VIEW, PARTS AND ORDERING INFORMATION

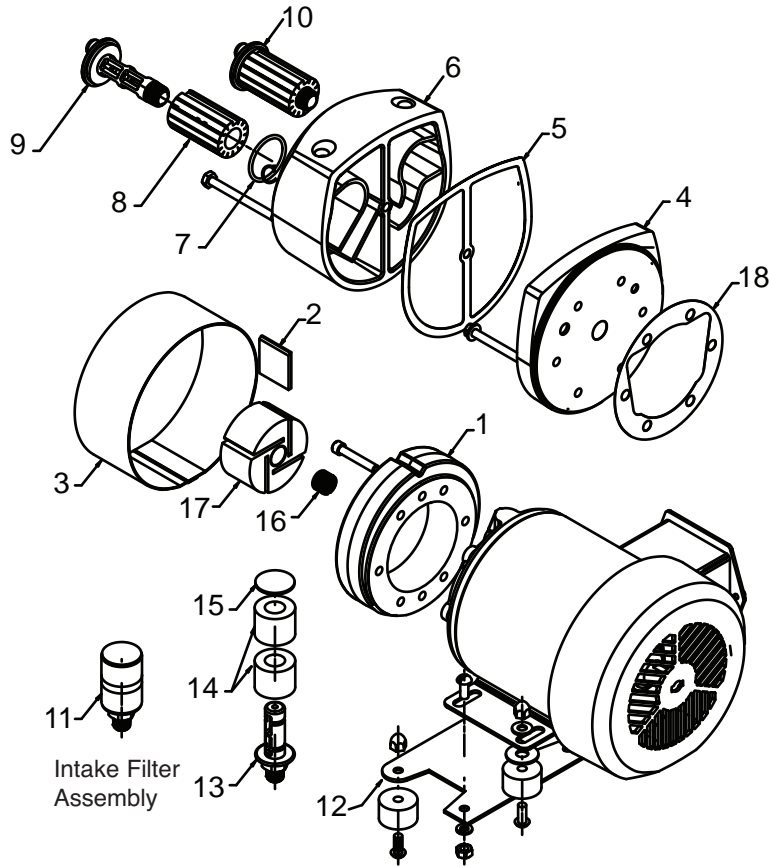

REF	DESCRIPTION	QTY	GAST PART#
1	BODY	1	AK500
2 *	VANE	4	AH850A
3	SHROUD	1	AK502B
4	END PLATE	1	AK501
5 *	GASKET	1	AK521
6	MUFFLER BOX	1	AK519
7 *	O-RING	2	AK473
8 *	FELT	2	AK524
9	END CAP	2	AK510
10	END CAP FILTER ASSEMBLY	2	AK526
11	FILTER / MUFFLER	1	B343B
12***	FOOT SUPPORT ASSM	1	AT209
13	FELT SUPPORT	1	B347
14 *	FELT FILTER	2	B344A
15	SCREEN CAP	1	AJ571
16	TOLERANCE RING	1	AH775B
17	ROTOR	1	AF105
18 *	GASKET AMBER	1	AL408
**	SERVICE KIT	1	K882/K886

\* Denotes parts included in the Service Kit. Parts listed are for stock models.

\*\* For specific OEM models, please consult the factory. When corresponding or ordering parts, please give complete model and serial numbers.

\*\*\*Foot support assembly optional on some models.



**PART NO. 70-299 (REV-C)**

**TROUBLESHOOTING CHART**

Low		High		Pump Overheat	Motor Overload	Reason and remedy for problem.
Vacuum	Pressure	Vacuum	Pressure			
●	●			●	●	Filter dirty. Clean or replace.
	●			●	●	Muffler dirty. Clean or replace.
●				●	●	Vacuum line collapsed. Repair or replace.
			●	●	●	Relief valve set too high. Inspect and adjust.
●	●					Relief valve set too low. Inspect and adjust.
●	●			●	●	Plugged vacuum/pressure line. Inspect and repair.
●	●					Vanes sticking. Clean or replace.
●	●					Vanes worn. Replace.
●	●			●	●	Foreign material- in pump. Inspect and clean.
●	●			●	●	Motor not wired correctly. Check wiring diagram and line voltage.

We have Gast Certified Service Centers throughout the world. For the most up-to-date listing, contact one of our sales offices below:

**Gast Manufacturing, Inc.**  
P.O. Box 97  
2300 Highway M139  
Benton Harbor, MI 49022  
Ph: 269/926-6171  
FAX: 269/925-8288  
[www.gastmfg.com](http://www.gastmfg.com)

**Gast Hong Kong**  
Unit 12, 21/F, Block B  
New Trade Plaza  
6, On Ping Street, Shatin  
N. T. Hong Kong  
Ph: (852) 2690 1066  
Fax: (852) 2690 1012  
[www.gasthk.com](http://www.gasthk.com)

**Gast Group Limited, United Kingdom**  
Unit 11, The I O Centre  
Nash Road  
Redditch, B98 7AS  
United Kingdom  
ph: +44 (0) 1527 504040  
Fax: +44 (0) 1527 525262  
[www.gastmfg.com](http://www.gastmfg.com)



ISO 9001 & 14001 CERTIFIED

[www.gastmfg.com](http://www.gastmfg.com)

©Registered Trademark/™Trademark of Gast Manufacturing Inc., Copyright ©2002 Gast Manufacturing Inc. All Rights Reserved.